

USBOutputs user manual

By : Manuel Vélez
Translation: Manuel Hernández-Peña M.

www.opencockpits.com

ver 1.0

INTRO

USBOutputs has been designed to control up to 64 outputs (each output up to 50 volts, 500 mA, with a maximum total current of 2,5 Amperes).

The card includes a pulse width modulation dimmer with 128 steps; this card is perfect to control leds, lamps for indicators and backlighting systems.

In addition, the card also implements 5 analogue inputs.

The card is connected to the PC via one USB port, and the controller is managed via IOCP protocol and SIOC software.

There is a specific testing software to make any test in a graphic way. This option is really interesting to configure the devices connected to the card.

TECHNICAL SPECIFICATIONS

- USB port connection
- Up to 64 digital outputs of 500 mAmperes.
- Up to 2.5 Amperes (total output) and 50 volts.
- 5 analogue inputs (8 bits).
- PWM Dimmer control (7 bits).
- Connection to SIOC software
- Visual software for testing and configuring.

CONNECTIONS

On the card you can find:

- 1) 64 quick connectors for outputs, numbered from 0 to 63.

Here we will connect the negatives (GND) of the leds or other elements with polarity.



- 2) One quick connector to feed the outputs, with positive and negative (GND).

Here we will connect the feed to be used with different elements (leds, lamps...).



- 3) One USB connector.



- 4) One connector for an external power source (optional connection).

Just in case the computer is not able to give enough power to the card, we can connect here a external 5 volts power source.



- 5) One connector for feeding the outputs (optional if we don't want to use the quick connector).

This is just the same connection as the one in the second point.



JUMPERS

The card has two jumpers named JMP1 and JMP2 :

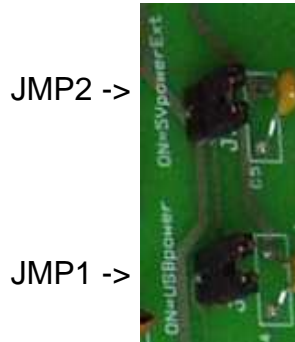

When the optional external power source is not connected, **JMP1** must be **closed** (this way the power will be taken from the USB port) and **JMP2** must be **open**.

If we want to connect an external power source (+5 volts DC), **JMP1** must be **opened**.

If we want to use the external power source (+5 volts DC) to feed the outputs too, we have to **close JMP2**.

! WARNING !

If an external power source different than +5 volts DC is connected to feed the outputs, and both JMP1 and JMP2 are closed, the card must be damaged.

CONNECTION DIAGRAM

As an example, we can see here how a group of lamps would be connected to the card and to the external power source.

We can see that the common point for the lamps is the positive. In the case of lamps is not important but in the case of polarized elements, like leds this is very important:

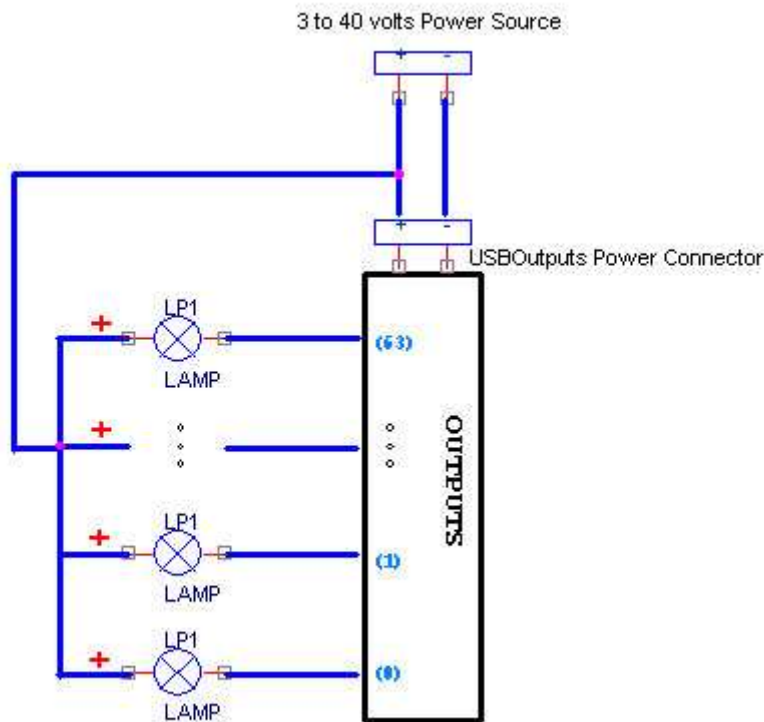

SOFTWARE

USBOutputs is controlled with SIOC software. SIOC has a programming system based on scripts. With this system, each output can be independently controlled.

Another specific software for this card is available and let us, in a visual mode, to test and configure the card.

test_outputs.exe SOFTWARE

This is the specific software for USBOutputs card. It detects any USBOutputs connected to the computer.

While the software is running, you can connect a card too, and the software will identify it and assign a device number depending in which USB port the card has been connected.

Choosing from a list the desired card, we can control the card parameters with this software.

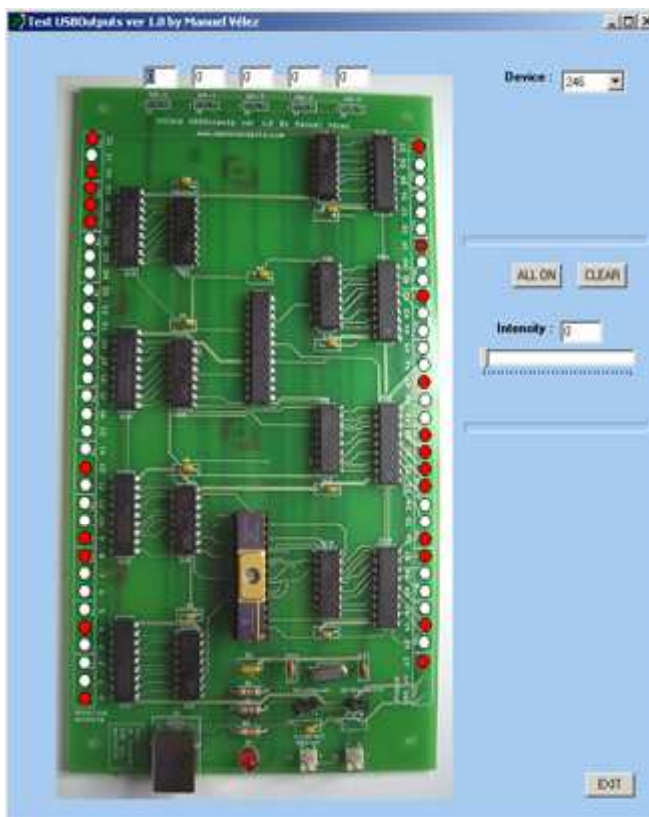

We can enable or disable any output by clicking on the card image shown on the software.

We can enable or disable all outputs by clicking on the corresponding buttons.

Information regarding analogue inputs are shown besides each one too.

The USB device number is shown on the right upper corner.

Using the card with SIOC

Check that you have installed **SIOC ver. 3.46 or later**.

The card must be identified in the devices list like USBOutputs with a device number. This number is very important in order to make individual configurations for different cards.

These numbers can be taken from the configuration software of the card.

For each card connected, we have to create a new line in the **sioc.ini** configuration file. Each line will define a sequential number for the card, and its device number. The format of this line is:

MASTER=(*sequential number*),6,1,(*device number*)

For example, if we have 3 USBOutputs cards, with device numbers 35, 42 and 44, we have to include the following lines in the **sioc.ini** file:

MASTER=1,6,1,35

MASTER=2,6,1,42

MASTER=3,6,1,44

The cards can be connected in the same computer where other IOCards products (Master, MCP, Multiradio...) are connected.

The only important thing is to define the information regarding device numbers correctly, as we can see in the following examples:

Outputs:

In the SIOC script, we have to define each output using the Master card format, as follows:

Var (*variable number*), **name** (*variable name*) , **Link** **IOCARD_OUT**, **Output** (*output number 0-63*), **device** (*device number defined in sioc.ini*)

For example, a valid output could be :

Var 230, name O_WARNING, Link IOCARD_OUT, Output 35, device 2

Inputs:

To read any of the analogue inputs, we have to use the following format:

Var (*variable number*), **name** (*variable name*) , **Link IOCARD_ANALOGIC**, **Input #**(*input number 1-5*), **PosL** (*minimum value*), **PosC** (*center value*), **PosR 255** (*maximum value*) , **device** (*device number defined in sioc.ini*)

For example, a valid input could be :

Var 2032, name POT1, Link IOCARD_ANALOGIC, Input #1, PosL 1, PosC 128, PosR 255, device 2

Dimmer control:

To control the light intensity, the format is:

Var (*variable number*), **name** (*variable name*) , **Link IOCARD_DISPLAY**, **Digit 1**, **Numbers 3** , **device** (*device number defined in sioc.ini*)

For example, a valid line could be :

Var 0008, name bright_c1, Link IOCARD_DISPLAY, Digit 1, Numbers 3

0 = Minimum intensity.

127 = Maximum intensity.

Software, circuits and information published in this document or on the site www.opencockpits.com are property of the developers, who give NO PERMISSION to use them with commercial purposes if an explicit and written authorization has not given.

Software, circuits, information and available codes can be freely redistributed, without any authorization, only if the author and the source site www.opencockpits.com is specified.